

# INSTRUCTIONS

FOR

## LV SERIES

### VENTURI LOADERS



Our PPE Venturi Hopper Loaders are a PPE exclusive only available from PPE. Do not confuse these with any other make, model or manufacturer.

© Copyright Plastic Process Equipment, Inc 2019

Revised 1-8-19

**PLASTIC PROCESS EQUIPMENT, INC.** [www.ppe.com](http://www.ppe.com) • e-mail: [sales@ppe.com](mailto:sales@ppe.com)

**PPE WEST** 6385 Montessouri Street, Las Vegas, Nevada 89113 702-433-6385 • 800-258-8877 • Fax: 702-433-6388

**PPE SOUTH** 11218 Challenger Avenue, Odessa, Florida 33556 727-834-8888 • 800-282-6783 • Fax: 727-834-8873

8303 CORPORATE PARK DRIVE, MACEDONIA (Cleveland), OHIO 44056, USA

Toll Free: USA, Canada & Mexico **800-362-0706**

216-367-7000 • Toll Free: 800-321-0562 • Fax: 216-367-7022 • Order Fax: 800-223-8305



# LV Series Venturi Loaders

## GENERAL DESCRIPTION

Please read this brief manual carefully before installation and using the machine to prevent damage or personal injuries. Venturi loaders use fast flowing pressurized air to create a vacuum that is used to convey various plastic granules. Air pressure required is around 71 to 85 P.S.I.





# LV Series Venturi Loaders

## FEATURES

- 1) Euro style, compact in size and weight.
- 2) Stainless steel material hopper and base avoids contamination of materials plus easy to clean polished surfaces.
- 3) Filtered exhaust air does not pollute environment.
- 4) Silent operation uses high-pressure air to convey materials, no motor noise.
- 5) Proximity switch sensor mounted next to the sight glass-tube assembly for accurate level sensing of material.
- 6) Compressed air regulator and filter eliminates moisture and maintains steady air pressure. Regulator control is located in the tamper proof control box.
- 7) Quick installation and simple to operate.

## NOTICE:

All service work should be carried out by a person with technical training or corresponding professional experience. The manual contains instructions for both handling and servicing. The Trouble Shooting section contains service instructions intended for service engineers. Other sections contain instructions for the daily operator.

## MODIFICATIONS:

**WARNING!** Do not modify this machine in any way. Modifications of any kind not only void any warranty, but it can cause serious injury or damage to personnel or equipment.



## PLASTIC PROCESS EQUIPMENT, INC.

www.ppe.com • e-mail: sales@ppe.com

**PPE WEST** 6385 Montessouri Street, Las Vegas, Nevada 89113  
702-433-6385 • 800-258-8877 • Fax: 702-433-6388

**PPE SOUTH** 11218 Challenger Avenue, Odessa, Florida 33556  
727-834-8888 • 800-282-6783 • Fax: 727-834-8873

8303 CORPORATE PARK DRIVE, MACEDONIA (Cleveland), OHIO 44056, USA

Toll Free: USA, Canada & Mexico  
**800-362-0706**

216-367-7000 • Toll Free: 800-321-0562 • Fax: 216-367-7022 • Order Fax: 800-223-8305



# LV Series Venturi Loaders

## TECHNICAL SPECIFICATIONS

PPE MODEL	Conveying Capacity (lbs/hr)	Compressed Air Required P.S.I.	Hopper Capacity (lbs)	Max. Conveying Distance (ft)	Conveying Hose I.D. (inches)	Discharge Hole Size	Length of Suction Probe (inches)	Dimensions (inches) H x W x D	Weight (lbs)
LV-50S	400	71 - 85	.63	20	1.25"	1.5"	39"	16" x 4.25" x 5.9"	6
LV-100S	400	71 - 85	3.50	20	1.25"	1.5"	39"	29" x 6.5" x 6.3"	8
LV-120S	400	71 - 85	3.71	20	1.25"	1.5"	39"	24" x 8.5" x 11"	10
LV-121SDF	800	4.10	20	1.25" (2)	2"	39" (2)	24" x 8.5" x 11"	12	

Note: Power supply 120V/60/1.

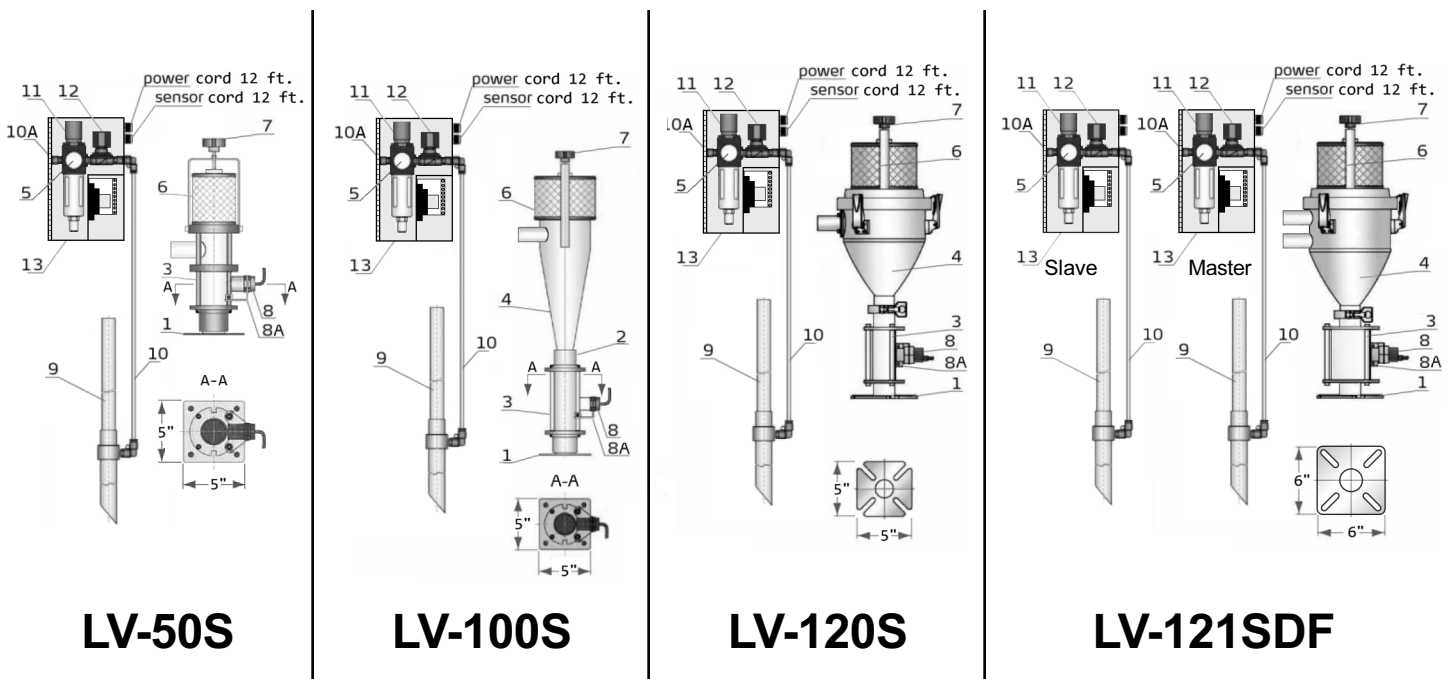

- |   |  |
|---|--|
| <ul style="list-style-type: none"> <li>1. Base</li> <li>2. O-ring</li> <li>3. Sight Glass Assembly</li> <li>4. Hopper, Stainless Steel</li> <li>5. Pressure Gauge</li> <li>6. Air filter</li> <li>7. Clamping Knob, Filter</li> <li>8. Sensor (Proximity Switch)</li> <li>8A. Sensor Bracket</li> </ul> | <ul style="list-style-type: none"> <li>9. Suction Probe 1-1/4" O.D., Venturi Type</li> <li>10. Air tubing 10mm (.395") poly x 13 ft. (Air out to probe.)</li> <li>10A. Air Supply (in)</li> <li>11. Compressed-air filter &amp; regulator (1/4" NPT)<br/>You must disconnect power supply before opening control box to adjust air pressure!</li> <li>12. Solenoid, Air</li> <li>13. Tamper Proof Control Box</li> </ul> |
|---|--|

© Copyright Plastic Process Equipment, Inc 2019



**PLASTIC PROCESS EQUIPMENT, INC.**

6385 Montessouri Street, Las Vegas, Nevada 89113  
 PPE WEST 702-433-6385 • 800-258-8877 • Fax: 702-433-6388

11218 Challenger Avenue, Odessa, Florida 33556  
 PPE SOUTH 727-834-8888 • 800-282-6783 • Fax: 727-834-8873

www.ppe.com • e-mail: sales@ppe.com

8303 CORPORATE PARK DRIVE, MACEDONIA (Cleveland), OHIO 44056, USA

216-367-7000 • Toll Free: 800-321-0562 • Fax: 216-367-7022 • Order Fax: 800-223-8305

Toll Free: USA, Canada & Mexico  
**800-362-0706**





# LV Series Venturi Loaders

## FUNCTIONS DESCRIPTION

Working Principle Illustration.

Venturi loaders use fast flowing pressurized air to create a vacuum that is used to convey various plastic granules. Air pressure is around 71 - 85 P.S.I.

The Venturi Loaders are not designed to convey powders. The maximum particle size to be conveyed is 3/16" pellets.

## SAFETY PRECAUTIONS

Transportation of the machine.

### TRANSPORTATION:

- 1) LV series are packed cardboard box.
- 2) Do not invert the machine and avoid collision with other objects during transportation to prevent improper functioning.
- 3) The structure of the machine is well-balanced, although it should also be handled with care when lifting the machine for fear of dropping it.
- 4) The machine and its attached parts can be kept at a temperature from -13°F to 131°F for long distance transportation and for a short distance; it can be transported with temperature under 158°F. contained within the tank.

General Warning Sign



SINGLE MATERIAL MODEL MACHINE HOPPER MOUNT

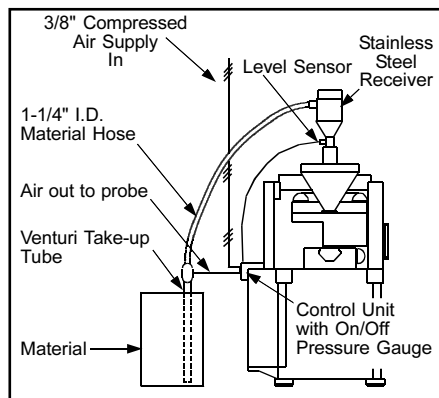

Standard Virgin Material Model illustrated. Can be hopper mounted or directly on machine feed throat for just in time material supply.

DUAL MATERIAL MODEL VIRGIN AND REGRIND

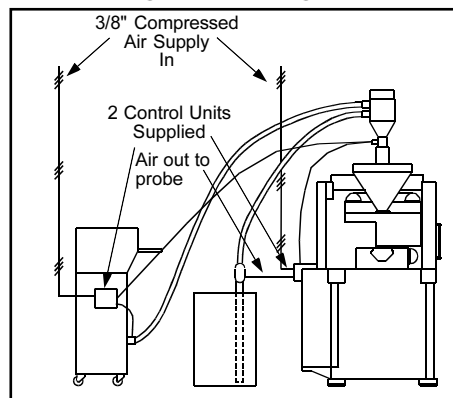

Dual Entry Virgin/Regrind Model illustrated. Unit will convey virgin and regrind simultaneously thus better mixing is provided.



**PLASTIC PROCESS EQUIPMENT, INC.**

www.ppe.com • e-mail: sales@ppe.com

**PPE WEST** 6385 Montessouri Street, Las Vegas, Nevada 89113  
702-433-6385 • 800-258-8877 • Fax: 702-433-6388

**PPE SOUTH** 11218 Challenger Avenue, Odessa, Florida 33556  
727-834-8888 • 800-282-6783 • Fax: 727-834-8873

8303 CORPORATE PARK DRIVE, MACEDONIA (Cleveland), OHIO 44056, USA

Toll Free: USA, Canada & Mexico  
**800-362-0706**

**PPE** 216-367-7000 • Toll Free: 800-321-0562 • Fax: 216-367-7022 • Order Fax: 800-223-8305



# LV Series Venturi Loaders

## SAFETY PRECAUTIONS

Storage of the machine.

### STORAGE:

- 1) LV Series should be stored indoors with temperature kept from 41°F to 104°F and humidity below 80%.
- 2) Disconnect all power and turn off main switch and control switch.
- 3) Keep the whole machine, especially the electrical components away from water to avoid potential troubles caused by the water.
- 4) Plastic film should be used to protect the machine from dust and moisture when not in use.

### WORKING ENVIRONMENT:

- 1) The machine should be operated indoors in a dry environment with max. temperature 113°F and humidity no more than 80%.

### DO NOT USE THE MACHINE:

- 1) If it has a damaged power cord.
- 2) On a wet floor or when it is exposed to moisture to avoid electrical shock.
- 3) If it has been dropped or damaged until it is checked or fixed by a qualified serviceman.
- 4) At least a clearance of 3 feet surrounding the equipment is required during **Operation**. Keep this equipment away from flammable sources at least 6 feet.
- 5) Avoid vibration, magnetic disturbance at the operation area.

### FIRE HAZARD:

- 1) In case of fire, CO<sub>2</sub> dry powder fire extinguisher should be applied.
- 2) Attention No need for regular inspection because all the electrical parts in the control unit are fixed tightly!



**PLASTIC PROCESS EQUIPMENT, INC.**

www.ppe.com • e-mail: sales@ppe.com

**PPE  
WEST**

6385 Montessouri Street, Las Vegas, Nevada 89113  
702-433-6385 • 800-258-8877 • Fax: 702-433-6388

**PPE  
SOUTH**

11218 Challenger Avenue, Odessa, Florida 33556  
727-834-8888 • 800-282-6783 • Fax: 727-834-8873

8303 CORPORATE PARK DRIVE, MACEDONIA (Cleveland), OHIO 44056, USA

216-367-7000 • Toll Free: 800-321-0562 • Fax: 216-367-7022 • Order Fax: 800-223-8305

Toll Free: USA, Canada & Mexico  
**800-362-0706**



# LV Series Venturi Loaders

## INSTALLATION

The Venturi Loader can be installed directly on the plastic material hopper. **CAUTION:** Be sure to fasten the loader in place as they are top heavy when conveying material plus the extra weight of the vacuum hose. Connect the venturi poly tubing 10mm x 13 ft. to the suction probe of the dryer or the material storage bin. Then connect the other point to the hopper, use the grounded wire 1-1/4" I.D. material hose and seal the mounting plate base touch-point. Next connect your in house air supply 10mm tubing to the inlet on the left side of the control box. Then connect the 10mm tubing between your pick-up probe and your control box, right side. Lastly connect the power supply. Pressure regulator is preset and contained in the sealed tamper proof control box. To reset operating air pressure, you must remove the control box cover, lift the pressure control knob, reset the pressure and lock the knob by pushing down until it clicks. **DO NOT reset air pressure with power on!!** For Dual Feed Model follow procedures as listed above except you have 2 hoses and suction pipes plus 2 control boxes. One control box is the Master (supplies power) and the second is the Slave. Plug the Slave box into the Master to energize the Slave box. Both control boxes have power switches so the Slave box (regrind) can be shut down if necessary.

## INSTALLATION SPACE

- 1) During installation of the Venturi Loader, keep at least 2 feet installation space around the Venturi Loader as shown by the picture.
- 2) Do not install the Venturi Loader in a position crowded with other objects. This could cause erratic operation or maintenance and repair problems.
- 3) Do not sit on the Venturi Loader.
- 4) Keep away from chemicals or flammable materials.
- 5) Discharge hole is 1-1/2".

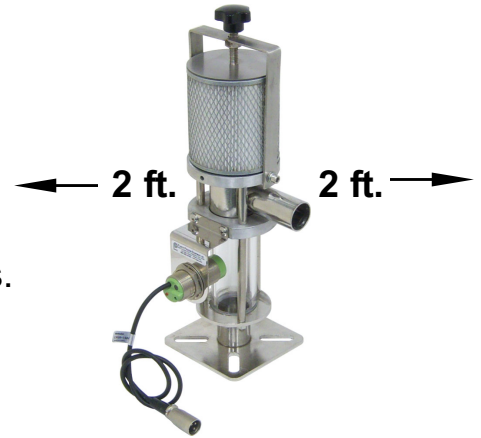

## CARE & MAINTENANCE

### Filter Cleaning or Maintenance

The filter is located on the material hopper. Clean or change the filter periodically or when loaders feeding capacity decreases. A blocked or dirty filter greatly reduces material conveying capacity!

### Clean steps:

Unscrew the star knob, remove the filter. Clean the dust on the filter or install a new filter to ensure you get maximum material conveying. **Keep your filter clean!!**

In order to avoid air-blocking and to get smooth conveying, please Periodically clean the dust on the filter (about once every week).



**PLASTIC PROCESS EQUIPMENT, INC.**

www.ppe.com • e-mail: sales@ppe.com

**PPE WEST** 6385 Montessouri Street, Las Vegas, Nevada 89113  
702-433-6385 • 800-258-8877 • Fax: 702-433-6388

**PPE SOUTH** 11218 Challenger Avenue, Odessa, Florida 33556  
727-834-8888 • 800-282-6783 • Fax: 727-834-8873

8303 CORPORATE PARK DRIVE, MACEDONIA (Cleveland), OHIO 44056, USA

216-367-7000 • Toll Free: 800-321-0562 • Fax: 216-367-7022 • Order Fax: 800-223-8305

Toll Free: USA, Canada & Mexico  
**800-362-0706**



# LV Series Venturi Loaders

## TROUBLE SHOOTING

Condition	Analysis
Looking for material for a long time, or Venturi Loader doesn't run.	The main switch and control switch doesn't open or the above two aren't connected properly, check this!
	The proximity sensor isn't connected well.
	The signal wire is broken.
	Loss of air pressure.
The hopper is full, but the Venturi Loader still runs.	The proximity sensor doesn't release.
	The signal wire is short circuited.
After several times of loading the material hopper is still empty.	The material storage tank is empty.
	The pipe has an air leak.
	The filter is blocked.
	The air pressure is too low.

## ELECTRIC DIAGRAM

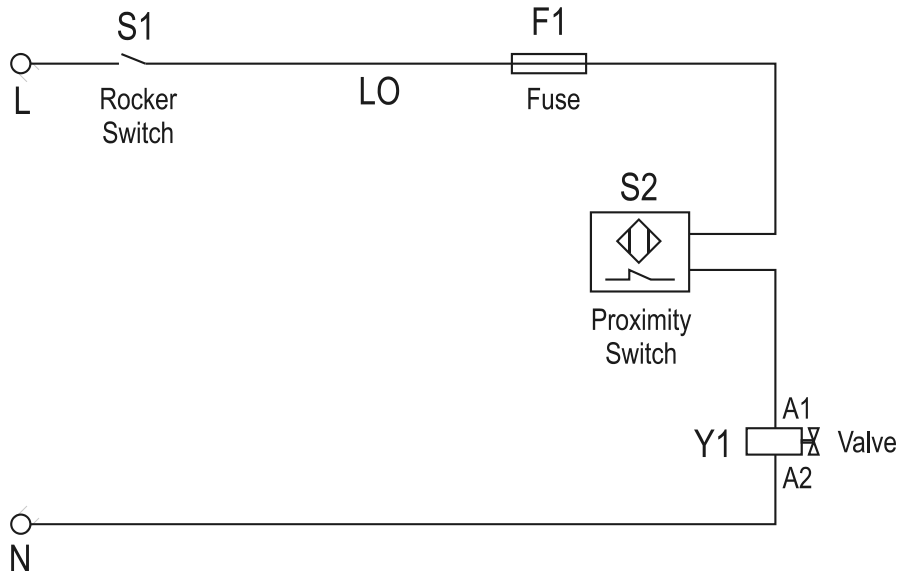

Symbol	Component Name	Model
S1	Rocker Switch, Power	120VAC-4P
S2	Proximity Switch	CR30-15DN
S2	Proximity Switch - Reverse Acting	K10054
Y1	Magnetic Valve	SMC-021-001C
F1	Fuse, 2A	AGC-2



**PLASTIC PROCESS EQUIPMENT, INC.**

www.ppe.com • e-mail: sales@ppe.com

**PPE WEST** 6385 Montessouri Street, Las Vegas, Nevada 89113  
702-433-6385 • 800-258-8877 • Fax: 702-433-6388

**PPE SOUTH** 11218 Challenger Avenue, Odessa, Florida 33556  
727-834-8888 • 800-282-6783 • Fax: 727-834-8873

8303 CORPORATE PARK DRIVE, MACEDONIA (Cleveland), OHIO 44056, USA

Toll Free: USA, Canada & Mexico  
**800-362-0706**

216-367-7000 • Toll Free: 800-321-0562 • Fax: 216-367-7022 • Order Fax: 800-223-8305