



# REGENERATIVE BLOWERS (VACUUM PUMPS)



## FOR DRYERS, PNEUMATIC CONVEYORS, VACUUM SYSTEMS, ETC.

### FEATURES

- 1/4 to 30 HP
- Air Flow to 950 SCFM
- Pressure to 11.5 psi
- Vacuum to 12" Hg
- Oil & Odor-free
- Single or 3-Phase
- Quiet: 53 to 81 db(A)



RoHS Compliant



**ISO-9001**  
MANUFACTURED IN A  
QUALITY SYSTEM CERTIFIED  
FACILITY.

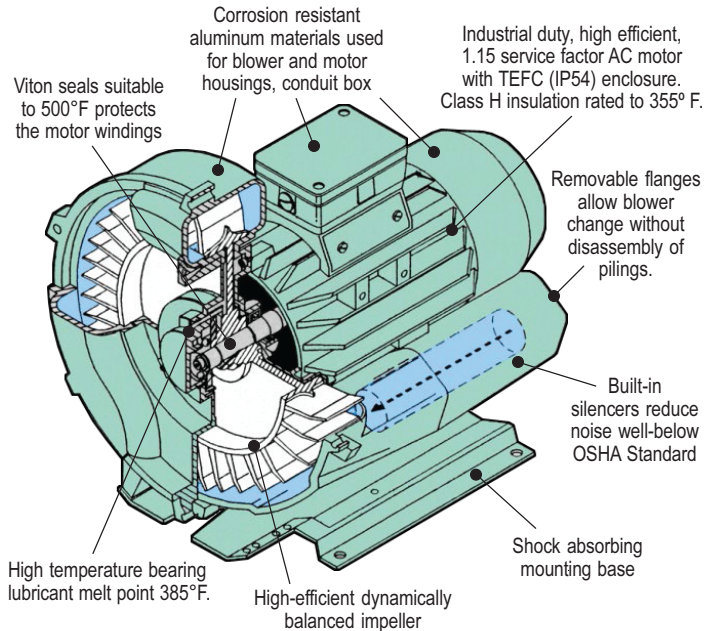

Manufactured since 1986, the All-Star Regenerative Blowers are the best choice for applications requiring a quiet, 100% oil-free, odor-free and non-pulsating air or gas supply. Regenerative Blowers are also referred to as side channel, vortex or ring-type blowers.

All-Star Regenerative Blowers (Vacuum Pumps) offer an alternative to traditional high pressure blowers and pumps. The regenerative blower is suitable for applications where positive displacement (PD-type) blowers and pumps have been used. It's simple design permits the units to be used as a blower or vacuum pump - without added parts.

### STRADDLE MOUNTED IMPELLER DESIGN

High bearing temperatures that prove fatal in competitive blowers are eliminated in the All-Star design because the bearings are mounted on the outside of the blower housing. Damaging overhung loads are eliminated in the All-Star design because a bearing is located on each side of the impeller. This design permits mounting the blower in any orientation, including vertical shaft up or down.

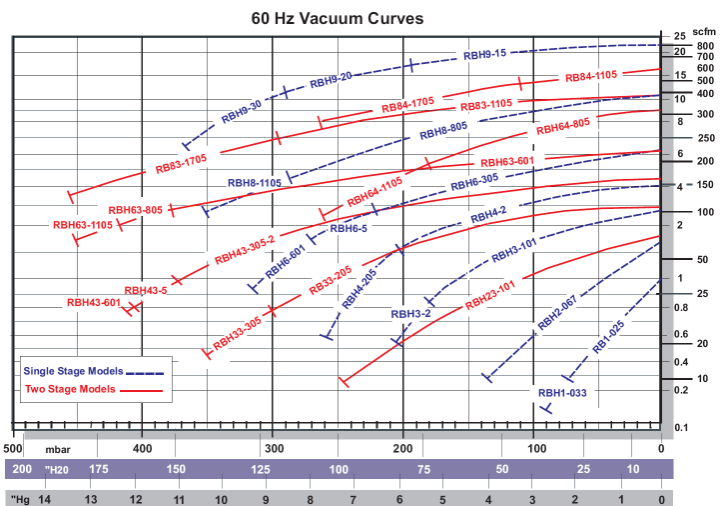
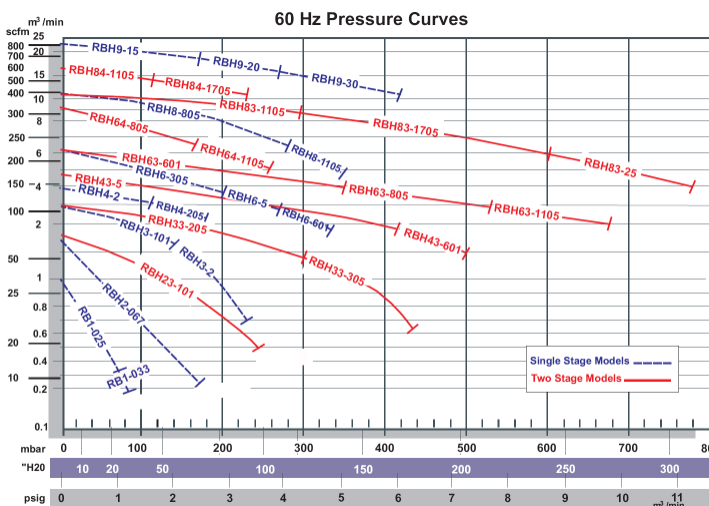
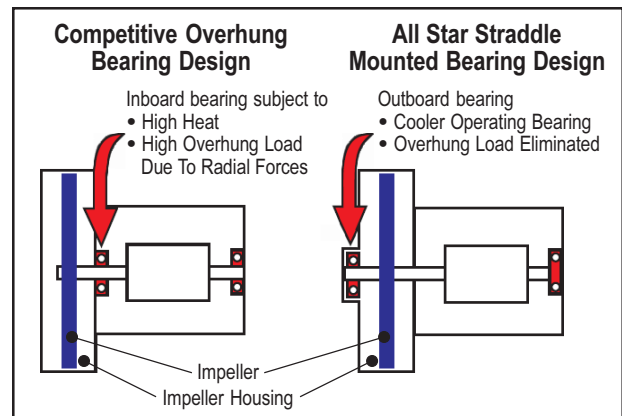

## PLASTIC PROCESS EQUIPMENT, INC.

8303 CORPORATE PARK DRIVE  
MACEDONIA, OHIO 44056-2300  
216-367-7000 • FAX: 216-367-7022  
TOLL FREE: 800-321-0562

6385 MONTESSOURI STREET  
LAS VEGAS, NEVADA 89113-1186  
702-433-6385 • FAX: 702-433-6388  
TOLL FREE: 800-258-8877

www.ppe.com  
e-mail: sales@ppe.com

Toll Free: USA, Canada & Mexico  
**800-362-0706**

Order Fax: 800-223-8305